

INSTALLATION MANUAL

REC PEAK ENERGY SERIES

For the installation of REC Peak Energy panels certified according to IEC 61215/61730

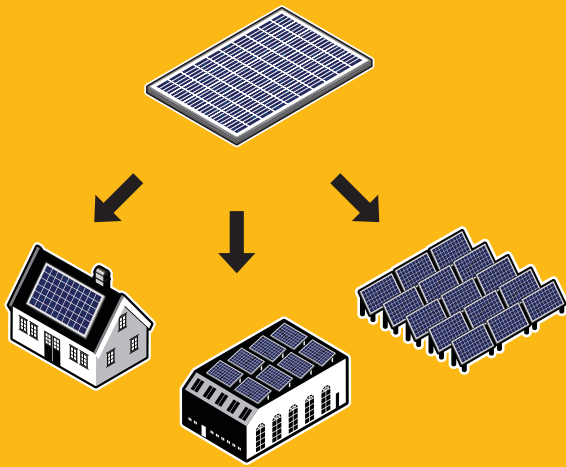

CONTENTS

TABLE OF FIGURES	2
INTRODUCTION	3
HOW TO USE THIS MANUAL	3
YOUR RESPONSIBILITY AS AN INSTALLER	3
SUPPORT	3
LIABILITY DISCLAIMER	3
LIMITED WARRANTY	3
ELECTRICAL INSTALLATION	4
ELECTRICAL REQUIREMENTS	4
I) APPLICATION CLASS	4
II) SYSTEM REQUIREMENTS	4
III) STRING CONFIGURATION	4
IV) STRING CONNECTION	4
V) WIRING LAYOUT	4
VI) JUNCTION BOX, CABLES, CONNECTORS	4
VII) ELECTRICAL RATINGS	4
SAFETY MEASURES	4
I) SAFETY IN THE WORKING AREA	4
II) PREVENTING CURRENT GENERATION	4
III) SPECIFIC HAZARDS OF DC ELECTRICITY	4
IV) SAFETY REQUIREMENTS	4
MECHANICAL INSTALLATION	5
FIRE GUIDELINES	5
ORIENTATION	5
ENVIRONMENTAL FACTORS	5
PANEL HANDLING	5
MOUNTING THE PANELS	6
I) RAIL SPECIFICATIONS	6
II) CLAMP SPECIFICATION	6
III) CLAMP MOUNTING POSITIONS	7
IV) MOUNTING HOLES	7
V) SLIDE-IN SYSTEMS	7
VI) DRAINAGE HOLES	8
VII) GROUNDING	8
CONNECTIONS AND CONNECTORS	8
PROTECTING THE CABLES	8
SECURING CABLES AND CONNECTORS	8
MAINTENANCE	9
CLEANING INSTRUCTIONS	9
SYSTEM INSPECTION	9
RECYCLING	9
DISPOSAL OF ELECTRICAL AND ELECTRONIC EQUIPMENT	9
ANNEX 1. INSTALLATIONS ON WATER PLATFORMS	10
PANEL INFORMATION	11
TECHNICAL CHARACTERISTICS	11
DECLARATION OF CONFORMITY	12
DOCUMENT HISTORY	13

TABLE OF FIGURES

Number	Title	Page	Number	Title	Page
Fig. 1	Rail positioning examples	6	Fig. 8	Recommended grounding	8
Fig. 2	Clamp specification	6	Fig. 9	Minimum bend radius	8
Fig. 3	Panel secured at four points	6	Fig. 10	Panel dimensions	11
Fig. 4	Clamping zones	7	Fig. 11	Frame cross-section and dimensions	11
Fig. 5	Mounting holes	7	Fig. 12	REC EC Declaration of Conformity	12
Fig. 6	Mounting using mounting holes	7			
Fig. 7	Drainage holes	8			



Caution: Only qualified personnel should perform work on photovoltaic systems such as installation, commissioning, maintenance and repairs. Be sure to follow the safety instructions for all system components. Ensure relevant local codes and regulations for health and safety and accident prevention are observed.

INTRODUCTION

Thank you for choosing REC photovoltaic panels. REC Peak Energy panels are ideal for delivering long-lasting and reliable power output. The panels have been created through intelligent design and are manufactured to the highest quality and environmental standards. With correct installation and maintenance, REC panels will provide clean, renewable energy for many years.

Please read this entire manual carefully. It contains critical information on safety, as well as detailed instructions for installation, operation and maintenance of this panel. Failure to follow the procedures contained within will invalidate the warranty (available to download from our website). Review all instructions and safety notes before working on the system. Failure to do so may lead to injury or damage to property.

HOW TO USE THIS MANUAL

This installation manual describes the procedures for mounting all REC Peak Energy solar panels in a photovoltaic array (all panels certified according to IEC 61215 and IEC 61730 standards), including panel variants with a black backsheet and/or a black frame (but excluding 72-cell panels) from hereon all referred to as REC Peak Energy panels. The drawings within refer to all frame, backsheet and cell color types and are meant to be a generic representation of the instructions detailed in the text. Review this entire manual before commencing installation of the panels and ensure you are working from the latest version. Throughout the manual, you will see icons which highlight important information or notes:



Indicates potential for damage to the array or property or personal safety.



Indicates important notes on best practice to help with the installation.

For further information on installation procedures, please call your panel distributor or contact your local REC Solar office. Details can be found at www.recgroup.com.

YOUR RESPONSIBILITY AS AN INSTALLER

Installers are responsible for the safe and effective installation and operation of the photovoltaic system and for adhering to all local and national standards and regulations. Prior to installation, check all applicable regulations and permits concerning solar systems and ensure all local directives are observed.

- Ensure the REC panels are in a suitable condition for use and appropriate for the particular installation and environment
- Use only parts that convene to the specifications set out in this manual
- Ensure a safe installation of all aspects of the electrical array



All equipment should be properly maintained and inspected prior to use.

SUPPORT

Do not attempt to install REC Peak Energy solar panels when you are unsure of the procedure or suitability. For questions or guidance with your installation, please call your distributor or contact your REC sales office, which can be found at: www.recgroup.com/en/contacts.

LIABILITY DISCLAIMER

REC SOLAR PTE. LTD. accepts no liability for the usability and functionality of its photovoltaic panels if the instructions in this guide are not observed. Since compliance with this guide and the conditions and methods of installation, operation, use and maintenance of the panels are not checked or monitored by REC SOLAR PTE. LTD., REC SOLAR PTE. LTD. accepts no liability for damage arising from improper application or incorrect installation, operation or maintenance. This does not apply to damages due to a panel fault, in cases of loss of life, bodily injury or damage to health or in the event of a grossly negligent breach of obligations on the part of REC SOLAR PTE. LTD. and/or in the event of an intentional or grossly negligent breach of obligations by a legal representative or vicarious agent. REC reserves the right to make changes or amendments to this manual at any time, without prior notice.

This document may be produced in different languages. If there is any conflict, the English language version shall be definitive.

LIMITED WARRANTY

The REC Limited Warranty is available to download from www.recgroup.com. Non-compliance with the instructions in this manual may be classed as improper installation or use and invalidate the Warranty. If you have any questions about installation and the Warranty validity, please contact REC's technical support.

ELECTRICAL INSTALLATION

ELECTRICAL REQUIREMENTS

i) Application Class

REC Peak Energy panels are rated for use in electrical application class A: Hazardous voltage (IEC 61730: higher than 50V DC; EN 61730: higher than 120V), hazardous power applications (higher than 240W) where general contact access is anticipated (panels qualified for safety through EN IEC 61730-1 and -2 within this application class are considered to meet the requirements for Safety Class II).

ii) System Requirements

REC Peak Energy panels are only for use where they meet the specific technical requirements of the complete system. Ensure other components will not cause mechanical or electrical damage to the panels. Only panels of the same type and power class should be connected.

iii) String configuration

When using string configuration, plan and execute it according to inverter manufacturer's instructions. The number of panels connected to an inverter must be within the inverter voltage limits and operating range. Do not exceed the total system voltage permitted by the manufacturer, nor under any circumstance exceed the maximum system voltage of 1000V. The maximum system fuse rating is 25A, the maximum reverse current is 25A.

iv) String connection

Panels connected in series must have the same amp rating. The maximum number of panels that can be connected in series depends upon system design, type of inverter and environmental conditions. There are no restrictions on the number of panels that may be connected in parallel. Panel configuration must correspond to the specifications of other system components e.g. inverter. Refer to the reverse current rating of the panel (indicated in the Technical Characteristics chapter or on the panel datasheet). Cables rated to the maximum system voltage must be used for connections between panels and inverters.

v) Wiring layout

To minimize voltage surges (e.g. indirect lightning strikes), cables of the same string must be bundled together so loops are as small as possible. String configurations must be checked before commissioning. If open circuit voltage (V_{oc}) and short circuit current (I_{sc}) deviate from specification, this may indicate a configuration fault. Correct DC polarity is to be observed at all times.

vi) Junction box, cables, connectors

The junction box on REC Peak Energy panels is rated IP67. All connectors and cables must be secure and tight as well as electrically and mechanically sound. UV-resistant cables and connectors approved for outdoor use must be used. Conductor gauge must be chosen to ensure DC power losses (voltage drop) are kept to a minimum (<1%).

Observe all local regulations when selecting cables. For string connections, use minimum 4 mm² or copper wires insulated for a maximum operating temperature of 90°C. Secure cables using UV-resistant cable ties or other device. Loose and unsecured cables must be protected from damage (e.g., mechanical, abrasion, sharp objects, animals). Avoid exposing cables to direct sunlight and permanent tension.

 **REC prohibits any modification to the panel, including the cutting of cables in order to change the connector type or the opening of the junction box unless explicitly authorized by REC. Doing so will invalidate the warranty.**

vii) Electrical Ratings

Electrical ratings are within 3% of measured values at Standard Test Conditions (STC). Allow for increased output of a panel as a result of conditions different to STC by multiplying the values of I_{sc} and V_{oc} by a factor of 1.25 (or according to local regulations for electrical system installation).

SAFETY MEASURES

All relevant codes and regulations should be referred to and observed as well as regulations on working at heights and fall protection.

i) Safety in the working area

Installation of REC Peak Energy panels may involve rooftop work. Ensure all local regulations regarding working at heights are followed. Before beginning work on a photovoltaic system, ensure all working surfaces are structurally sound and capable of bearing the weight of employees and required equipment. Remember to isolate the system from the grid before carrying out any maintenance or repair work.

ii) Preventing current generation

To prevent the panels automatically generating current (electricity) when exposed to light, shield the system with a non-transparent cover during installation, maintenance or repair work.

iii) Specific hazards of DC electricity

Solar panels generate direct current (DC). Once current is flowing, breaking or opening a connection (e.g. disconnecting two panels) can cause an electrical arc. Unlike low voltage AC wiring, DC arcs are not self-extinguishing. They are potentially lethal burn and fire hazards:

- Follow panel and inverter manufacturers' installation, handling and operating instructions.
- Remove/open the inverter AC fuse/circuit breaker before disconnecting from the public grid.
- Switch off or disconnect the inverter and wait for the time specified by the manufacturer before commencing work. High-voltage components need sufficient time to discharge.

iv) Safety requirements

The voltage produced by a single panel and panels connected in series (voltages added together) or in parallel (currents added together) can be dangerous. Although the fully insulated plug contacts on the panel's output cables provide touch-safe protection, the following points must be observed during handling to avoid the risk of sparking, fire hazards, burns and lethal electric shocks.

- Exercise extreme caution when wiring panels and look out for damaged or dirty cables etc.
- Never insert metallic or other conductive objects into plugs or sockets.
- Ensure that all electrical connections are completely dry before assembly.
- Keep all materials, tools and working conditions dry and tidy.
- Use appropriate safety equipment e.g. nonslip footwear, insulated gloves and insulated tools.
- Solar panels produce current when exposed to sunlight. Do not connect the system to the inverter during solar exposure.

MECHANICAL INSTALLATION

FIRE GUIDELINES

REC Peak Energy panels have a Class C Fire classification. Utilize the following fire safety guidelines when installing REC Peak Energy panels:

- Check with local authorities for fire safety guidelines and requirements for any building or structure on to which the panels will be installed.
- The system design must ensure that it can be easily accessed in the event of a building fire.
- Check with local authorities for applicable regulations concerning setbacks or other placement restrictions that may apply for roof-mounted arrays.
- The use of DC ground fault interrupters is recommended. This may also be required by local and national codes.
- All electrical appliances are a fire risk. The panel must therefore be mounted over a fire retardant roof covering rated for the application and a distance of 60 mm between the panel and the mounting surface, allowing free circulation of air beneath the panels must be respected at all times.

ORIENTATION

To maximize system output, panels should be installed at the optimum orientation and tilt angle. The specifics of this depend on location and can be calculated by a qualified system designer.

 **Dependent on local conditions, a lower angle of installation will potentially increase the requirement for regular cleaning.**

The optimal mounting position of panels results in the sun's rays falling perpendicular (i.e. at 90°) to the surface. All panels in a string should, wherever possible, have the same orientation and tilt to ensure the system does not underperform due to mismatched outputs.

 **The panels should not be exposed to artificially concentrated light.**

ENVIRONMENTAL FACTORS

REC Peak Energy panels are designed to provide decades of durable and stable output. Ambient operating temperatures must be between -40 and +85°C.

The panels are not suitable for installation in potentially hazardous locations nor should they be installed in the following locations:

- Near sources of flammable gases or vapors e.g. gas stations, gas containers or spray paint facilities.
- Near open flames.
- Under water or in water features.
- Where exposed to sulfur e.g. near sulfur springs or volcanoes.
- Where the panels may be exposed to harmful chemicals.

 **Ensure panels are not exposed to direct contact with salt water/spray and avoid installation in areas subject to high salt mist content.**

PANEL HANDLING

Panels should be handled with care and protected from damage at all times. All warnings and instructions on the packaging should be observed. Follow these guidelines when unpacking, transporting or storing the panels:

- Record the serial numbers prior to installation and note the information in the system documentation.
- Carry the panels using both hands and do not use the junction box as a grip.
- Do not allow the panels to sag or bow under their own weight when being carried.
- Do not subject the panels to loads or stresses, e.g., leaning on them or through the placing of weight on them.
- Do not stand on the panels.
- Avoid dropping the panels as any damage caused may be unseen.
- Keep all electrical contacts clean and dry.
- Store panels in a dry and properly ventilated room.
- Do not apply force to the backsheet.
- Avoid using sharp or pointed objects if panels require marking.
- Never apply paints, adhesives or detergents to the back of the laminate.
- Do not use any solar panel that is damaged or been tampered with.
- Never attempt to disassemble, modify or adapt the panels or labels in any way as this will void the warranty.

 **Do not use a panel which is broken or damaged. If the panel front glass is broken or laminate back sheet is damaged, it can expose personnel to hazardous voltages.**

MOUNTING THE PANELS

REC Peak Energy panels are designed for capturing solar radiation and are not suitable for installation as overhead or vertical glazing. The junction box on the rear of the panel is protected to IP67 and allows panels to be mounted in any orientation.

⚠ The panels must be installed so that the cells are not shaded as this will drastically reduce electrical output. If partial shading is inevitable at certain times of the day or year, it must be kept to an absolute minimum.

There are different options for securing an REC Peak Energy panel, depending on the design of the array. Ensure the mounting structure design can withstand anticipated loads. Mounting hardware is not supplied by REC. Follow the mounting hardware manufacturer's instructions and recommendations at all times.

⚠ Remove any labels or stickers that may be on the front of the panels (where applicable) and ensure no residue is left on the glass.

★ Ensuring sufficient airflow and adequate cooling of the panels can help improve performance. There must be a minimum distance of 60 mm between the uppermost part of the roof and the lowest part of the panel.

i) Rail specifications

REC Peak Energy panels are typically installed on a rail-based mounting system. If using mounting rails, ensure they run under the frame or parallel to the frame (fig 1), directly under the clamping zones (fig 4).

Fig. 1: Rail positioning examples:

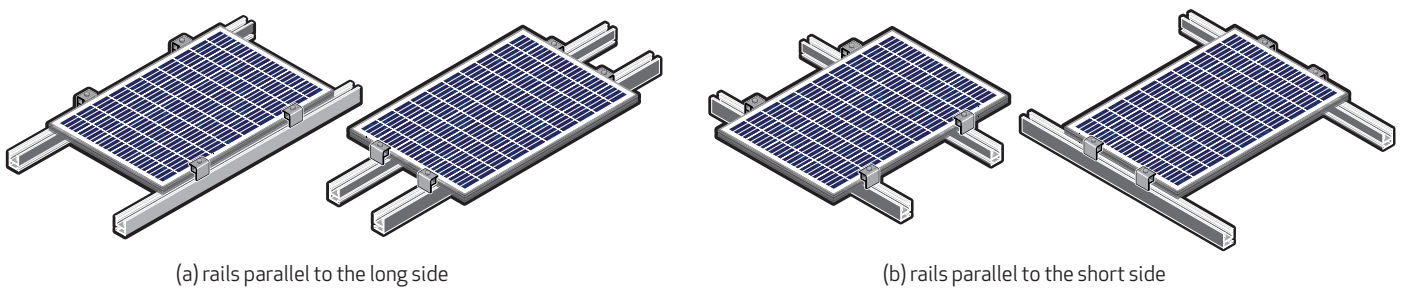

★ The overlap between the support rail and the outer edge of the frame must be a minimum of 6 mm.

ii) Clamp specification

Ensure the clamps used are suitable for the planned installation and expected system design loads.

Fig. 2: Clamp specifications

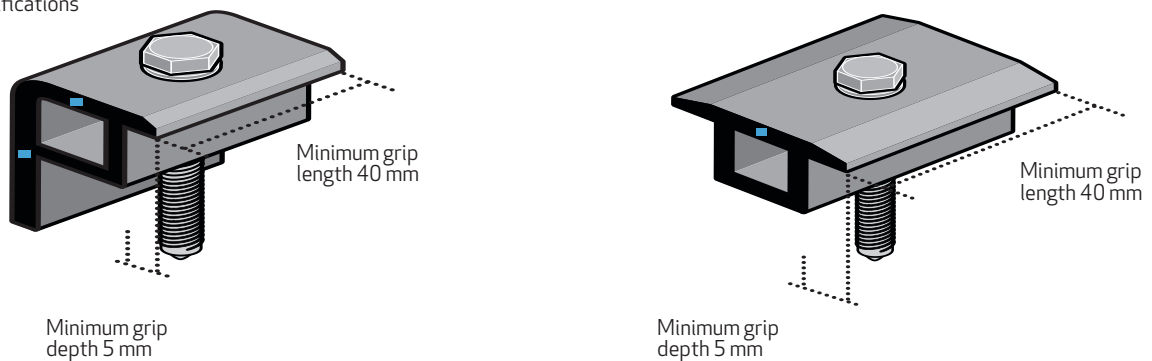

- The panel must be clamped by a minimum of two clamps per side (four clamping points per panel) (fig 3).
- Minimum grip length of 40 mm, minimum grip depth of 5 mm (fig. 2). The grip must not overlap the panel frame and cause shading.
- Use appropriate bolted connections as per clamp manufacturer's instructions.
- Follow the clamp manufacturer's recommended applied torque to fasten the clamps.

Fig. 3: Panels secured at four points.

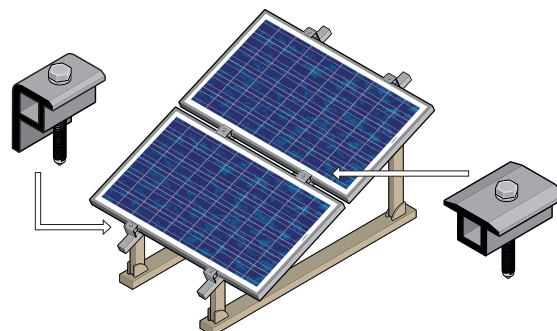

⚠ In areas of snow build-up panels can be subjected to forces in excess of the stated limit even when snow depth does not appear extreme, causing damage to the framework. If the installation is likely to be affected by this, further suitable panel support is recommended on the lower row of panels.

iii) Clamp mounting positions

The panels can be fixed on both the long and the short side of the panel within the constraints shown in fig. 4 with a minimum of four clamps. The panels are built to withstand a downward force of up to 5400 Pa (550 kg/m²) or 2400 Pa (244 kg/m²) according to where they are clamped. Site-specific loads such as wind or snow which may exert forces in a different way need to be taken into consideration to ensure this limit is not exceeded for each respective mounting option.

- Clamping within the green zone (208 - 416 mm) is certified for design loads up to 5400 Pa (550 kg/m²)
- Clamping within the yellow zone (0 - 208 mm long side, 250 mm short side) is certified for design loads up to 2400 Pa (244 kg/m²)
- Clamping within the red zone is not permitted (> 416 mm long side, > 250 mm short side) when only using four clamps

Fig. 4: Clamping zones

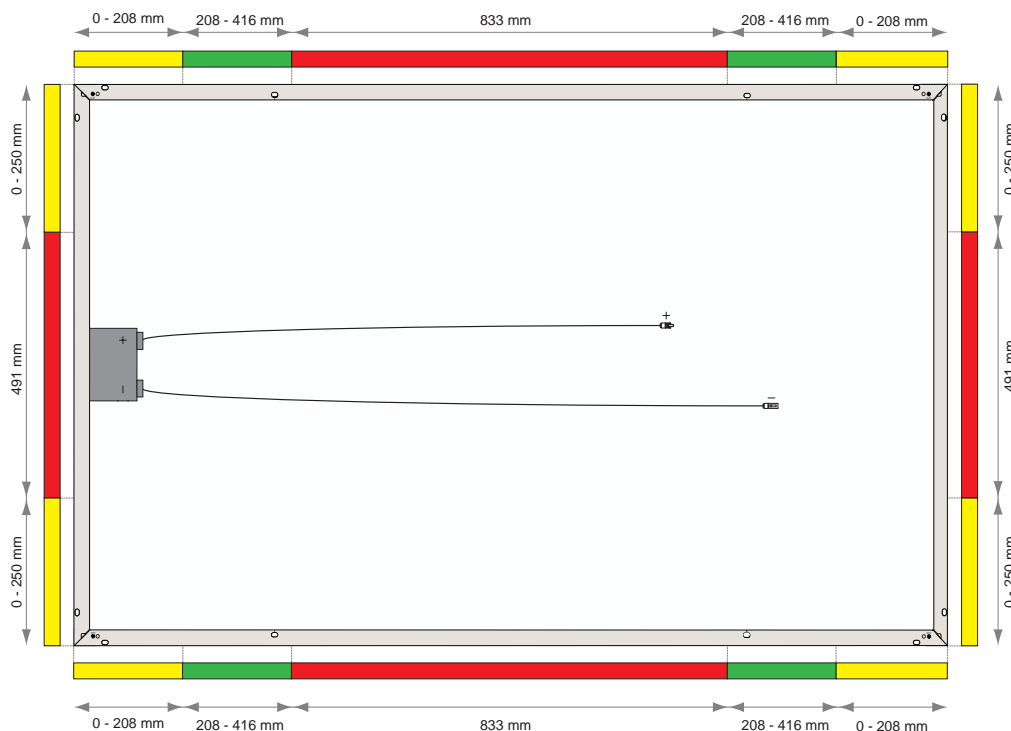

⚠ A minimum of four clamps must be fully located in the same colored zone to be certified to that value. If the panel is secured by four clamps in two different zones (i.e. green and yellow), it is certified to the lowest value only.

iv) Mounting holes

REC Peak Energy panels can also be secured to the mounting structure using the mounting holes (fig. 5) found on the underside of the frame (6.6 x 11 mm, spaced 450 mm from the midpoint of the long side). Bolts of size 6 mm secured with 6 mm locking nuts with a flange should be used to secure the frame to the mounting structure (fig. 6). Observe the following procedures when using mounting holes:

- The mounting construction should be of aluminium or galvanized steel to avoid galvanic corrosion and be appropriate for the local environment.
- Additional electrical bonding to Ground is required for the support structure (see Grounding).
- All four mounting holes in the frame must be used.
- Tighten fastenings using a torque wrench according to the understructure manufacturer's instructions.

⚠ The product warranty will be voided if additional holes are made in the frame. All fixing and fastening materials must be corrosion resistant.

Fig. 5: Mounting holes

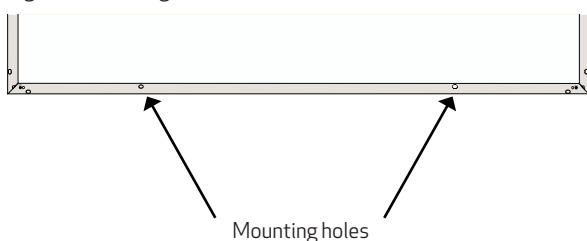
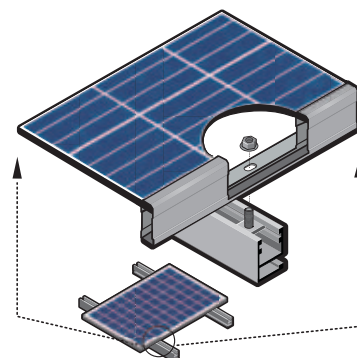

Fig. 6: Mounting using mounting holes



v) Slide-in Systems

REC Peak Energy panels may also be installed using slide-in systems. Such mounting systems must meet the same specifications regarding grip lengths and depths as clamps and be able to withstand the correct load pressures. When installing with slide-in systems, the drainage holes (fig. 7) must not be covered. For any questions regarding installation on such systems, please contact REC directly.

vi) Drainage holes

Each corner of the panel frame has small drainage holes (fig. 7) to allow water caused by rain or snow melt to exit the frame easily and to minimize damage caused by freezing and thawing. These must not be used for mounting the panel.

! Ensure the drainage holes are not covered by the mounting structure.

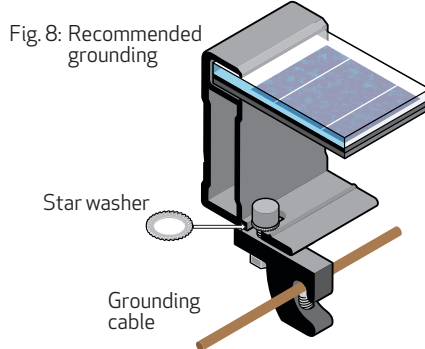
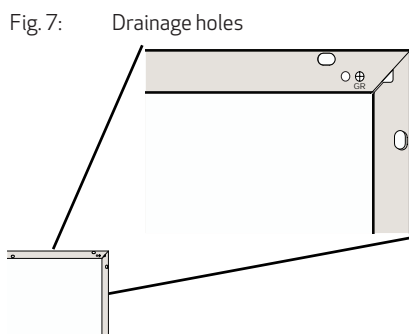

Grounding dimensions and wire fastening torque:

Cross section [mm ²]	Type	Torque [Nm]
13.3 - 21.2	Stranded	3.9
8.4	Stranded	3.4
2.1 - 5.3	Stranded / Solid	2.8

vii) Grounding

Local regulations may require grounding of the panels. Check all applicable requirements before beginning installation. Where grounding is necessary, it must be done using an electrical connection from the panel frame:

- Suitable grounding lugs must be used.
- Grounding cable size should be between 2.1 mm² - 21.2 mm².
- Attach grounds to the grounding holes in the panel frames.
- Fix lug to the frame using a star washer and lock nut, ensuring a conductive connection (fig. 8).
- Place the star washer between the frame and the nut, using a 5 mm diameter stainless steel bolt and locking nut to mount the lug to the panel frame and tighten according to the manufacturer's recommended torque.

★ To avoid galvanic corrosion, stainless steel fastening materials are preferred, however galvanized or hot dipped zinc plated fasteners are equally suitable.

CONNECTIONS AND CONNECTORS

In order to ensure durable and safe connections between panels and BOS equipment, the following instructions must be followed in order to protect the electrical connections from the elements. More detailed information is given in the Guide to Best Practice - Connections and Connectors which can be found via the REC website Download Center (www.recgroup.com/downloads).

CONNECTORS

- Connectors must be securely joined to each other according to the manufacturer's instructions. REC explicitly excludes the cutting of cables and replacement of connectors. If this causes an issue for a particular site, contact REC via www.recgroup.com for further advice.
- The use of any chemicals or lubricants on the connectors or contacts must be carried out in line with the connector manufacturer's instructions.

PROTECTING THE CABLES

- To prevent stress on the junction box casing, ensure the cable exits the junction box in a straight line before any bend in the cable.
- The cables on REC Peak Energy panels have a minimum bending radius of 30 mm to avoid damage to the insulation (Fig. 9).
- Ensure cables do not hang loose where they may be damaged through friction or stress, e.g., caused by wind or grazing animals.
- Shield connectors from falling or dropping water by locating them directly beneath a panel.
- Cables must be firmly secured to the structure, without overtightening, as this can deform the cable insulation.

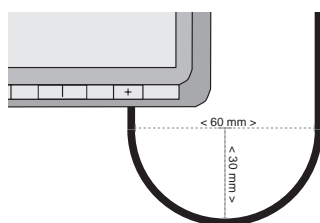

Fig. 9: Minimum bend radius of 30 mm and cable exiting the junction box

SECURING CABLES AND CONNECTORS

- When securing the connector, place it away from the mounting structure with sufficient air circulation all around. This allows the connector to dry effectively and avoids the risk of damage or degradation of the connection.
- Good practice is to secure the cable either side of the connectors, ensuring no stress is exerted on the connector casing or cable entry.

! To enable correct cooling and drying of the connectors, do not add extra protection to the connector, e.g., heat shrink, grease or tape.

MAINTENANCE

CLEANING INSTRUCTIONS

REC Peak Energy panels have been designed for easy maintenance. Normal rainfall will naturally clean the panels if installed at a sufficient angle. The need for cleaning will vary dependent on location, rainfall, pollution and angle of installation – the lower the angle of installation, the more cleaning will be required. To optimize electrical output it is recommended to clean the panels when dirt can be seen on the glass surface.



Cleaning of the panels should be carried out in the early morning when the panels are cool to avoid thermal shock.

If dirt remains on the panel, it may cause cell shading which will reduce power output or even cause further damage. To clean either the front or rear of the panels, use only deionized water at ambient temperature and a sponge, microfiber cloth or a soft brush to wipe away the dirt (rainwater, tap water or diluted alcohol may also be used as a secondary solution). For further cleaning a mild, biological and biodegradable washing-up liquid may be used.

When cleaning the panel, take care not to scratch the surface or introduce foreign elements that may cause damage. Ensure the water used is free from grit and physical contaminants that may damage the panel. Always rinse the panel with plenty of water. If soiling remains on the panel, repeat the cleaning process. If stains require more effort to be removed, Iso-propyl alcohol of a concentration less than 10% may be used. Acid or Alkali detergent may not be used



Use of high pressure hoses or cleaners is not permitted as these may damage the panel, laminate or cells.

Using a rubber squeegee, wipe the panel surface from the top downwards motion to remove any residual water from the panel glass. Panels can be left to dry in the air or wiped dry with a chamois. Avoid putting pressure on the panel surface when drying.

For more information on cleaning REC panels, consult the Cleaning Information Sheet available to download from the online REC Download Center www.recgroup.com/downloads.

SYSTEM INSPECTION

The system should be inspected regularly to ensure that:

- Fixtures and fasteners are secure, tight and free from corrosion.
- Electrical connections and housing are secure, tight, clean, and free of corrosion.
- The mechanical integrity of the cables is intact.
- Bonding points to ground are tight, secure and free from corrosion (which could break the continuity between the panels and ground).

RECYCLING

REC has made every effort to ensure panel packaging is kept to a minimum. The paper and cardboard packaging can be recycled and the protective wrapping and panel separating blocks are also recyclable in many areas. Recycle according to local guidelines and regulations.

DISPOSAL OF OLD ELECTRICAL AND ELECTRONIC EQUIPMENT (APPLICABLE TO E.U. COUNTRIES ONLY)



For installations in the European Union, this product is subject to WEEE regulations. The symbol above indicates that this product shall not be treated as household waste and must be disposed of at an appropriate collection point for the recycling of electrical and electronic equipment. The recycling of the different components and materials will help to conserve natural resources.

By ensuring REC Peak Energy panels are disposed of correctly, you will help prevent potential negative consequences for the environment and human health which could otherwise be caused by inappropriate waste treatment. For more information about recycling of this product, visit www.recgroup.com/products and click the recycling link; alternatively please contact your local recycling authorities or recycling center.

ANNEX 1. INSTALLATIONS ON WATER PLATFORMS

REC Peak Energy panels have not been certified for installation on water platform-type mounting systems. When installing REC Peak Energy panels on fixed position (e.g., anchored) water platforms, for example, floating pontoons, follow the instructions below specific to such applications. Failure to do so will invalidate the warranty.

 **For all installations on water platforms, first advise REC before the start of installation in case of any site specific instructions or constraints**

INSTALLATION ENVIRONMENT

i) Installation site

- REC panels may only be installed on closed bodies of fresh water where water salinity does not exceed 25 mS/cm at 25°C (15 PSU). This specifically excludes mounting on sea and ocean applications.
- The maximum permitted wave height must not exceed 1 m from the crest to the trough of the wave.

ii) Floating platforms

- When using a floating platform, follow the manufacturer's instructions regarding installation, maintenance, inspection and cleaning at all times.

iii) Minimum installation height

- The minimum installation height of REC Peak Energy panels is 15 cm and is defined as the height between the water surface and the lowest edge/part of the panel during normal operation. This will help to shield the panel from direct water spray.

INSTALLATION INSTRUCTION

i) System installation

- All cables used for the installation must have sufficient length and slack to prevent damage due to water level changes and wave motions.

 **Negative system grounding is required for REC Peak Energy panels installed on a floating platform**

ii) Mounting panels

- Installation of REC Peak Energy panels must be in accordance with the aforementioned standard mounting instructions.
- The junction box should be oriented as far as possible from the water surface according to system design and the junction box, cables and connectors must be protected from direct water splash.

iii) Panel protection

- In areas with high avian activity, additional bird repelling devices may be installed as long as they do not adversely affect system performance.
- If using lightning protection equipment on the floating installation, all relevant local regulations must be respected.

MAINTENANCE

- Regularly inspect the installation to ensure all panels are securely mounted.

 **For installations with high avian activity, system cleaning may be required at more frequent intervals to reduce shading of panels caused by bird defecation**

SAFETY

- Immediately disconnect the system if the installation or the floating platform exhibits deviation from standard operating conditions.
- In the event of the floating platform being submerged, disconnect the DC connection at the inverter immediately. Do not attempt to salvage panels when sunlight is present.

PANEL INFORMATION

TECHNICAL CHARACTERISTICS

Fig. 10: Panel dimensions (mm)

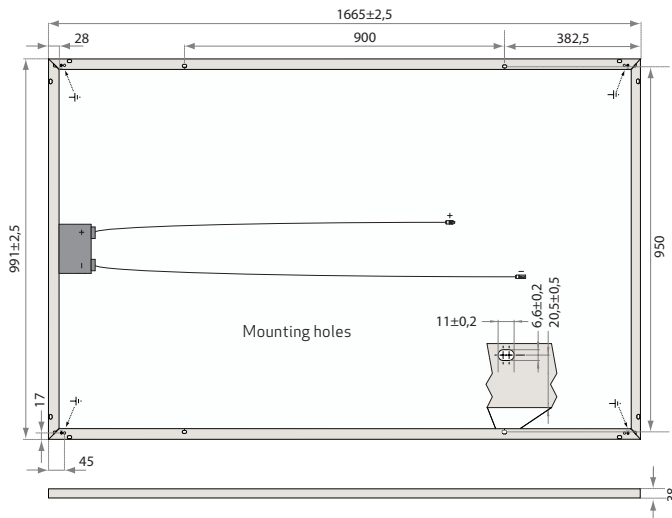
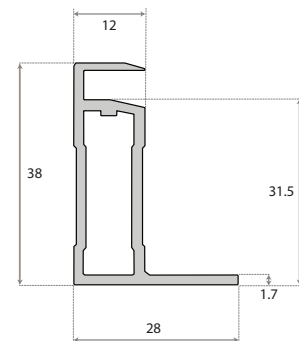

Fig. 11: Frame cross-section and dimensions (mm)



MECHANICAL DATA

Dimensions	1665 x 991 x 38 mm
Area	1.65 m ²
Weight	18 kg

MAXIMUM RATINGS

Operational Temperature	-40 ... +85°C
Maximum System Voltage	1000 V
Maximum Snow Load (IEC 61215)	550 kg/m ² (5400 Pa)
Maximum Wind Load (IEC 61215)	244 kg/m ² (2400 Pa)
Max Series Fuse Rating	25 A
Max Reverse Current	25 A

GENERAL DATA

Cell Type:	REC PE multi-crystalline
Glass:	3 strings of 20 cells with bypass diodes 3.2 mm solar glass with anti-reflection surface treatment
Back Sheet:	Double layer highly resistant polyester (white)
Frame:	Anodized aluminium (silver)
Junction Box:	IP67 rated
Connectors:	4 mm ² solar cable, 0.6 m + 0.6 m Multi-Contact MC4 (4 mm ²)

ELECTRICAL DATA @ STC	235 WP	240 WP	245 WP	250 WP	255 WP	260 WP	265 WP	270 WP
Nominal Power - P _{MPP} (Wp)	235	240	245	250	255	260	265	270
Watt Class Sorting - (W)	0/+5	0/+5	0/+5	0/+5	0/+5	0/+5	0/+5	0/+5
Nominal Power Voltage - V _{MPP} (V)	29.5	29.7	30.1	30.2	30.5	30.7	30.9	31.3
Nominal Power Current - I _{MPP} (A)	8.06	8.17	8.23	8.30	8.42	8.50	8.58	8.66
Open Circuit Voltage - V _{OC} (V)	36.6	36.8	37.1	37.4	37.6	37.8	38.1	38.4
Short Circuit Current - I _{SC} (A)	8.66	8.75	8.80	8.86	8.95	9.01	9.08	9.18
Panel Efficiency (%)	14.2	14.5	14.8	15.1	15.5	15.8	16.1	16.4

Analysed data demonstrates that 99.7% of panels produced have current and voltage tolerance of ±3% from nominal values. Values at standard test conditions STC (airmass AM 1.5, irradiance 1000 W/m², cell temperature 25°C). At low irradiance of 200 W/m² (AM 1.5 and cell temperature 25°C) at least 95.5% of the STC panel efficiency will be achieved.

EC DECLARATION OF CONFORMITY

We,

REC Solar Pte Ltd.
20 Tuas South Avenue 14
Singapore 637312
Singapore

hereby declare that the following product lines:

**REC Peak Energy Series, REC Peak Energy BLK Series, REC Peak Energy Eco Series,
REC Peak Energy EU Series and REC Peak Energy Integrated Series**

including the **RECxxxPE, RECxxxPE (BLK), RECxxxPE EU, RECxxxPE ECO and RECxxxPEI**
(where xxx indicates watt classes from 205 to 285 in increments of 5)

are in conformity with the provisions of the following EC directive:

LDV 2006/95/EC Low Voltage Directive

The following references of standards and technical specifications have been applied in this EC/EEA Declaration of Conformity:

IEC/EN 61215 : 2005 Crystalline silicon terrestrial photovoltaic (PV) modules - Design and qualification and type approval.

IEC 61215 (ed. 2)

IEC 61730-1 : 2004 Photovoltaic (PV) module safety qualification

IEC 61730-2 : 2004

IEC 61730 (ed. 1)

IEC 61730 (ed. 2)

EN 61730-1 : 2007

EN 61730-2 : 2007

The above mentioned products therefore correspond to EC Directive 204/108/EEC.

This product was first marked with the CE mark in 2010.

A handwritten signature in black ink, appearing to read 'Ter Soon Kim', is written over a faint, larger version of the signature.

Ter Soon Kim
Senior Vice President - Operations

Singapore, January 1, 2014

DOCUMENT HISTORY

Date	Revision Number	Reason
01.2010	A	First release
02.2010	B	Textual updates
02.2010	C	Textual updates
03.2010	D	Textual updates
05.2010	E	Textual updates
07.2010	F	Textual updates
03.2011	G	Textual updates, update of electrical data
09.2012	H	Release of separate IEC 61215/61730 and UL1703 specific installation manual version.
01.2013	I	Revised Technical Data. New clamp and rail specification.
08.2013	J	Textual updates (note on modifications to the panel)
11.2013	K	Textual updates (notes on panel handling, operating temperature, PV Cycle), Declaration of Conformity
04.2014	K.2	Textual updates
08.2014	L	Addition of sections on 'Connections and Connectors' and WEEE recycling, update of grounding hole dimension to 5 mm
12.2014	L.2	Textual updates (backsheet colors)
12.2014	L.3	Revision of low light behaviour in Electrical Data
01.2015	M	Addition of Annex 1, Installations on Water, textual updates to include product variants



REC SOLAR PTE. LTD.
20 TUAS SOUTH AVENUE 14
SINGAPORE 637312
SINGAPORE
Tel: +65 6495 9228
Mail: post@recgroup.com

www.recgroup.com